

NEW

Fired Marine Boiler

FMB-VF

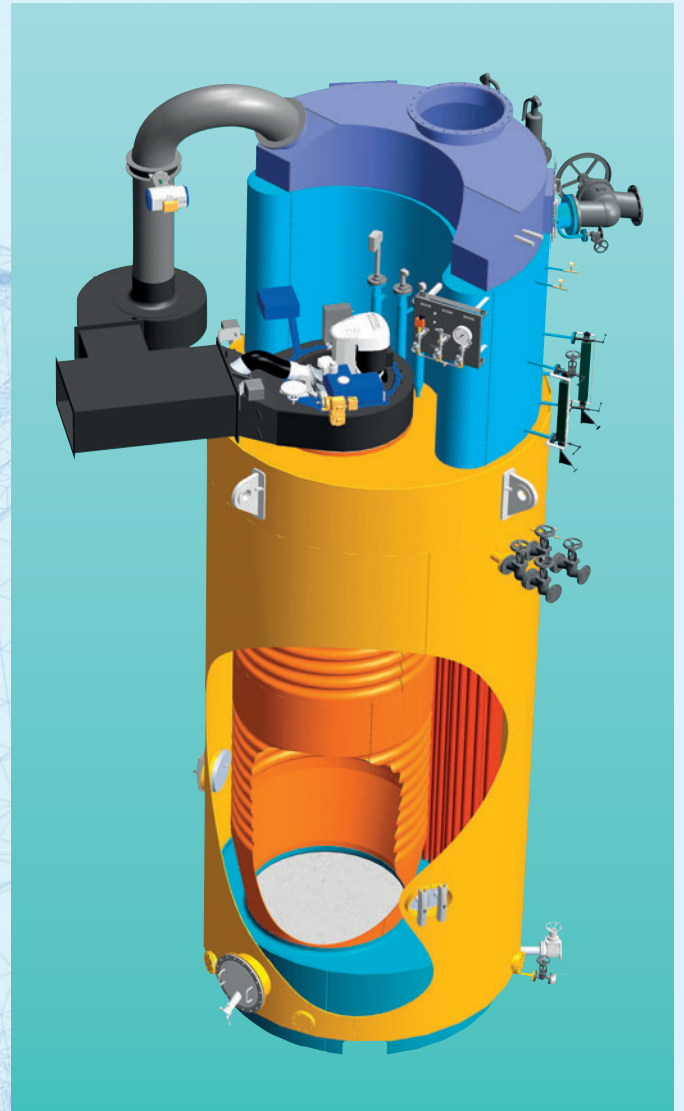
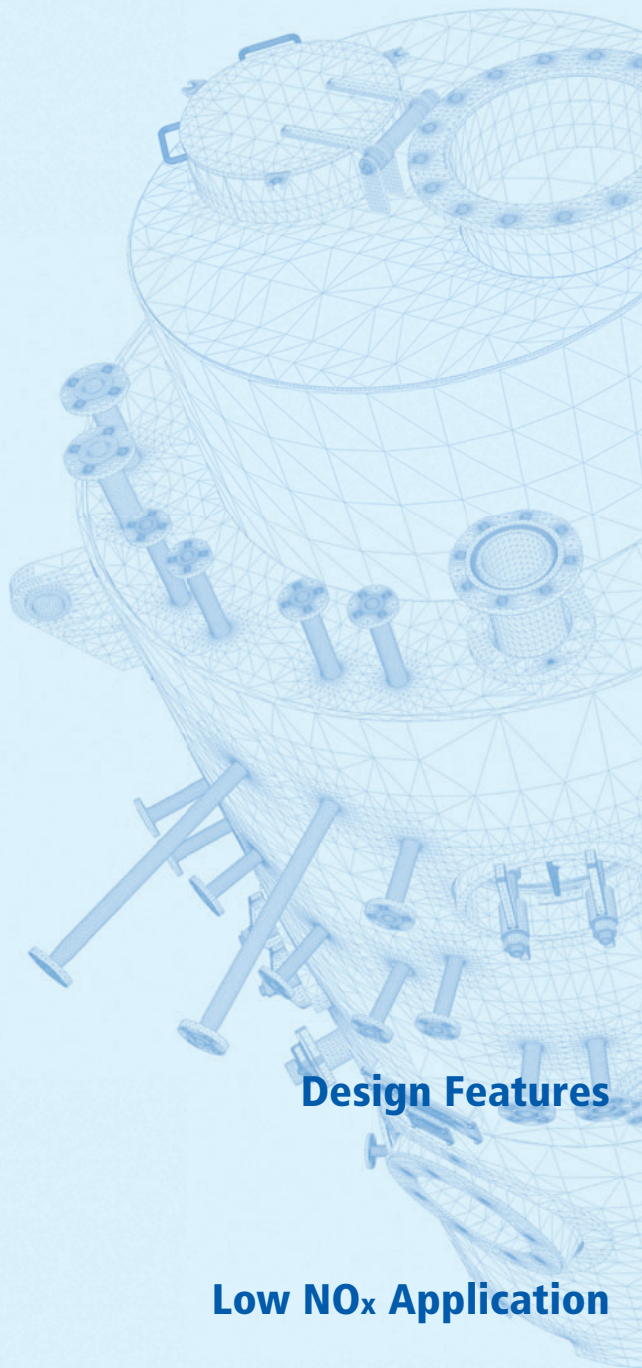

Capacity	up to 18 t/h
Design pressure	up to 1.0 MPa

Design Features

The FMB-VF is a vertical two-pass fired boiler. The heat transfer is performed through the corrugated or plain flame tube furnace and a number of plain smoke tubes. The new design of the flame tube entrance allows a minimum of burner refractory which enhance the operation reliability significantly.

Low NO_x Application

The FMB-VF is designed to incorporate Low NO_x Combustion Systems. In order to meet lowest emission levels the Low NO_x Combustion Systems are equipped with flue gas recirculation. This flue gas recirculation in conjunction with MGO fuels will allow boiler operation in ports worldwide as well in the future, as it reflects the latest developments on- and off-shore. For HFO firing the combustion system can be equipped with water injection to improve also solid particle emission levels.

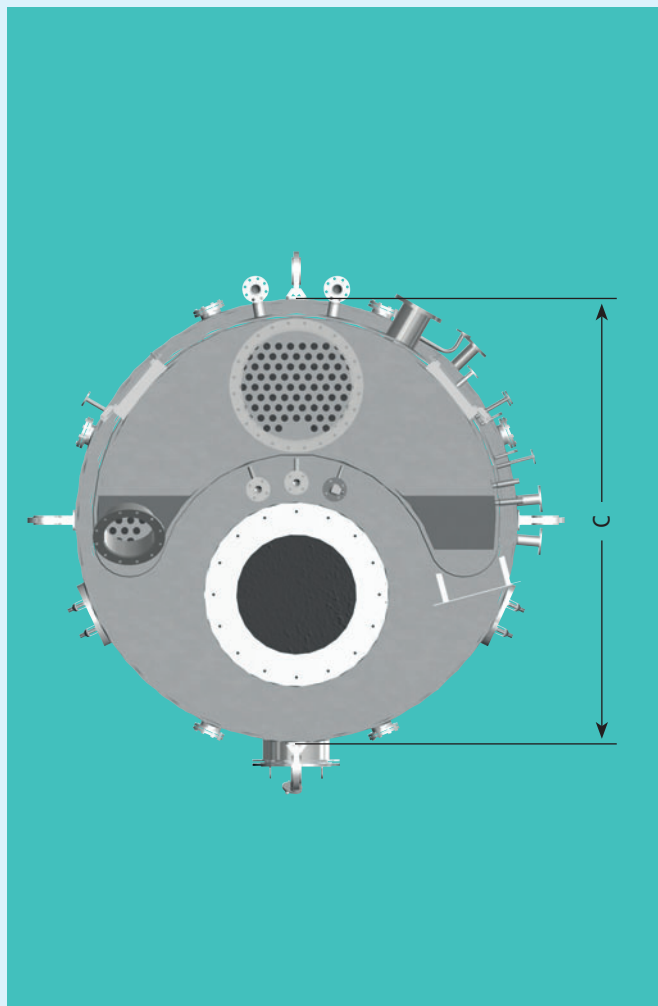
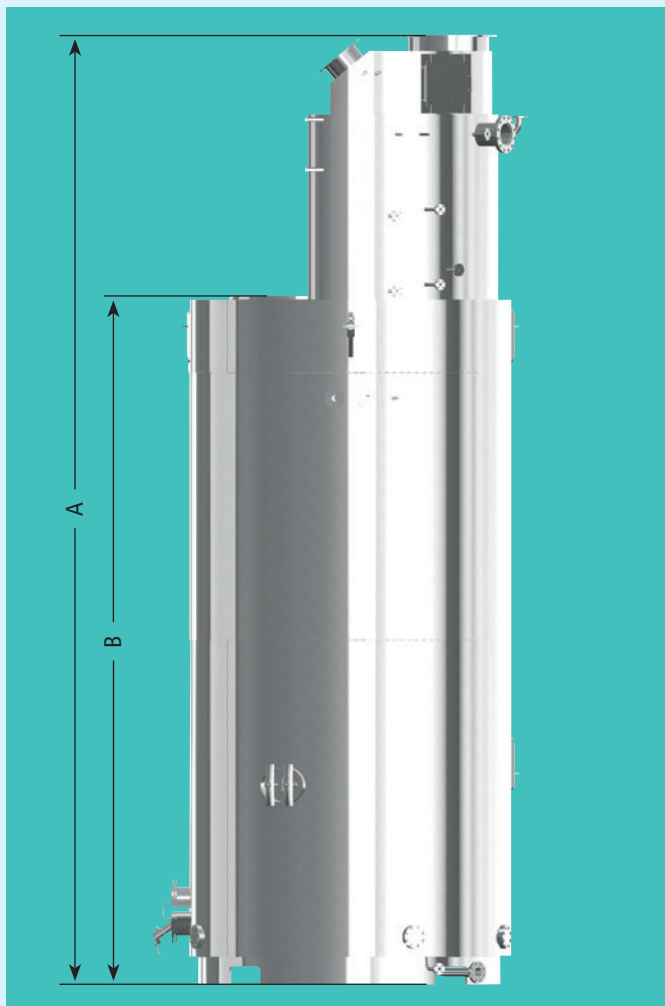

Steam capacity t/h	Design pressure MPa	A mm	B mm	C* mm	Boiler dry weight** kg	Water volume at NWL m ³	Recommended burner type***
6	1.0	7350	6600	2200	15800	8.6	SKV 50
8	1.0	7650	6900	2450	19000	11.3	SKV 60
10	1.0	8050	7300	2600	22400	13.2	SKV 80
12	1.0	8400	7650	2750	25900	15.5	SKV 100
15	1.0	8800	8050	3000	31500	19.7	SKV 150
18	1.0	9200	8450	3150	35800	22.4	SKV 150

* including insulation

** including insulation, refractory, valves and recommended burner

*** please note that recommendation of burner type is based on 60Hz frequency, for 50Hz applications, the burner type may be different

Dimensions A, B and C as well as weight and water volume may differ for systems with forced circulation exhaust gas economisers which use the FMB-VF boiler as steam separator.